

## ▶ The screen in front is a Rotar Cleaner

A Rotar Cleaner is a rotating screening drum, which separates, mixes and cleans various materials in one continuous motion. With the Rotar Cleaner, a simple physical principal is translated to a useful attachment for the recycling, demolition and earthmoving industries.

A Rotar Cleaner can be installed on wheeled loaders, excavators, backhoe loaders etc. Loading and unloading is easy with the Rotar Cleaner. By means of a hydraulic cover, the drum can be opened and easily used as a standard digging bucket.



During the rotation, the fine's fall out of the drum and the bigger sizes stay in. By use of various sizes of changeable screens, different effects can be realized.

With the rolling effect of the material, which stays in the drum, a cleaning reaction is realized by scouring.

## ▶ Applications:

- Topsoil cleaning
- Excavation of graveyards
- Cleaning of contaminated soils
- Clearance of Anti Personnel Mines
- Brick cleaning
- Beach-cleaning
- Back filling of cable and pipelines
- Composting
- Recycling of rubble

The pleasant operation, the basic maintenance, the high productivity and the great versatility turn the Rotar into an investment, which pays itself back in short time.

**"Your excavator was not so versatile before"**

## ▶ Rotar Cleaner

### ▶ Sorting /Demolition Grab

### ▶ Tyne Re-handling Grab

### ▶ Segregator bucket

### ▶ Scrap Shear

### ▶ Jawcrusher bucket



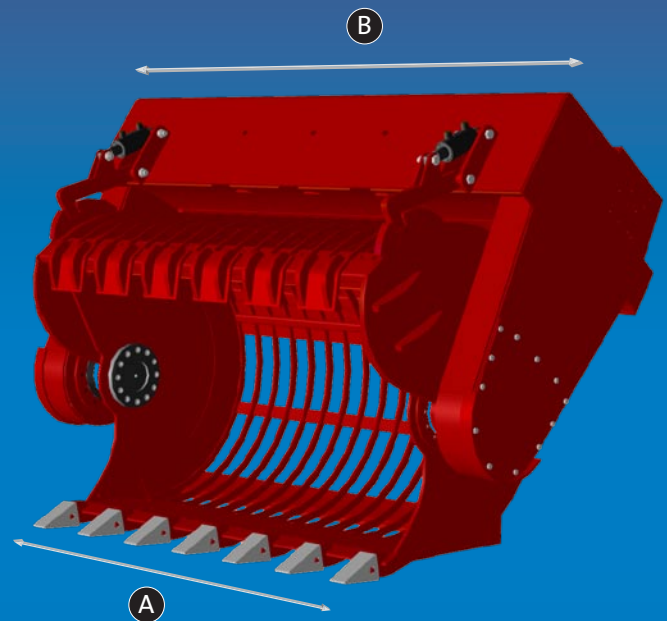
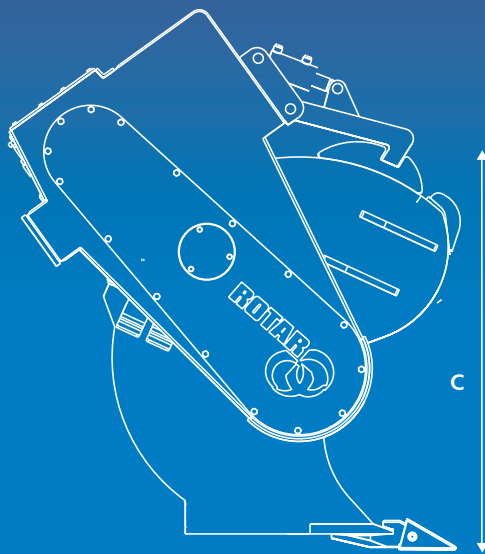

Type HEX	Drum Capacity (l)	Drum Weight (kg)*	Sizes (mm)			Operation pressure min./max(bar)**	Oilflow (l/min.) ***	Machine Weight (t)
			A	B	C			
HEX 350 M	350	425	885	1290	705	120/250	A 75/B 75	7-12
HEX 700 S	650	900	1170	1640	835	120/250	A 75/B 75	13-15
HEX 850 S	870	1200	1585	2055	835	120/250	A 75/B 75	15-20
HEX 1000 S	1050	1700	1130	1750	1075	120/250	A 125/B 125	20-25
HEX 1400 S	1450	2150	1565	2185	1075	120/250	A 125/B 125	25-35

Specifications may change without prior notice

- \* Weight exclusive flat hinge-plate, without screens
- \*\* Operation pressure 20 - 60 higher with B-hydraulics
- \*\*\* A=A-hydraulic / B=B-hydraulic

#### Hydraulica:

Rotar Cleaner is available in A-and B-hydraulics:

**A-hydraulic:** Carriermachine has to be provided with a proportional regulative, reversible hydraulic third valve spool

**B-hydraulic:** Carriermachine only has a black/white hydraulic spool with one flowdirection, e.g. a hammervalve

**C-hydraulic:** Carriermachine has to be provided with 2 proportional regulative, reversible hydraulic valve spools

#### Options:

Exchangeable insert screens from spring steel in # 6 / 10 / 15 / 20 / 25 / 30 / 35 / 40 and 45 mm

*Your Attachment Supplier*