

Specifications

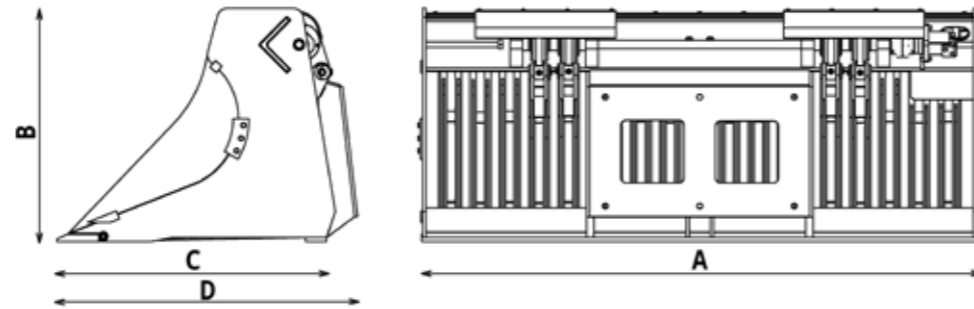

Ingenious, reliable, service-friendly and maximal productivity.
That is the power of Rotar!

Type EVB	600 S	800 S	1200 S	1200 I
Information				
Machine class (t)	13 - 18	16 - 25	21 - 35	21 - 35
Weight (kg)*	1130	1426	1965	1950
Volume (l)	600	800	1200	1200
Dimensions				
Dimension A (mm)	1200	1560	1610	1610
Dimension B (mm)	1275	1275	1275	1295
Dimension D (mm)	1400	1400	1695	1720
Attachment				
Rotar Hole-pattern	140 - 150	140 - 150	140 - 150	140 - 150
Hydraulics				
Max. operating pressure motor (bar)	140	140	140	140
Max. oil volume (L/min)	70 - 100	70 - 100	70 - 100	70 - 100

Grid spacing for all EVB machines = 42mm, except the EVB 1200I with 80mm.

Type RVB	800 S	950 S	1500 S	2000 S	2300 I
Information					
Machine class (t)	4.5 - 7.5	6 - 9	7.5 - 10	10 - 12	12 - 15
Weight (kg)*	860	950	1500	1800	2260
Volume (L) SAE 1: 2	1025	1155	1650	2050	2225
Dimensions					
Dimension A (mm)	2060	2320	2440	2650	2800
Dimension B (mm)	995	995	1166	1166	1166
Dimension C (mm)	950	950	1136	1286	1485
Dimension D (mm)	1112 - 1214	1112 - 1214	1283	1433	1570
Attachment					
Rotar Hole-pattern	430	430	450	450	450
Hydraulics					
Max. operating pressure motor (bar)	140	140	140	140	140
Max. oil volume (L/min)	75	75	75	75	75

* Weight exclusive adapterplate with bracket.

** Technical specifications are subject to change without prior notice.



RVB/EVB-Series

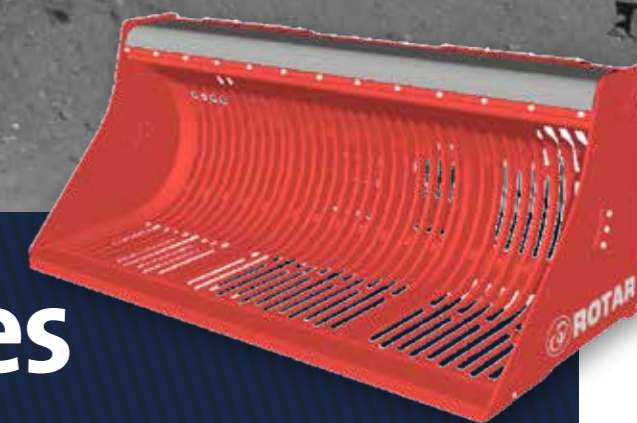

Rotar International BV

Address De Blokmat 11, 8281 JH Genemuiden (NL)

Tel. +31(0) 38 385 54 71

Fax +31(0) 38 385 54 02

E-mail info@rotar.com

Website www.rotar.com

03/2025



RVB/EVB

Rotar Segregator Bucket

The Rotar Segregator Bucket is a jack of all trades. Whether you are breaking up and cleaning paving slabs, clearing construction and demolition sites, or sorting debris and soil – it is the perfect attachment for you.



Robust driveline

This functional and multi-deployable Rotar Segregator Bucket is fitted with a robust driveline. The eccentrics on the driveline create a back-and-forth motion of the rip-sections. Driveline maintenance is very simple, and every lubrication point is easily accessible.

Hydraulic system

Processing a huge volume of materials every hour takes no more than connecting two hydraulic hoses to the excavator or wheel loader. The segregator bucket's hydraulic system is protected against peak pressures and excessive oil volumes. Customers can also have the Rotar Segregator Bucket fitted with replaceable teeth on the cutting edge.



GET THE
RED CRUSH!